

RF ROLL
FOR

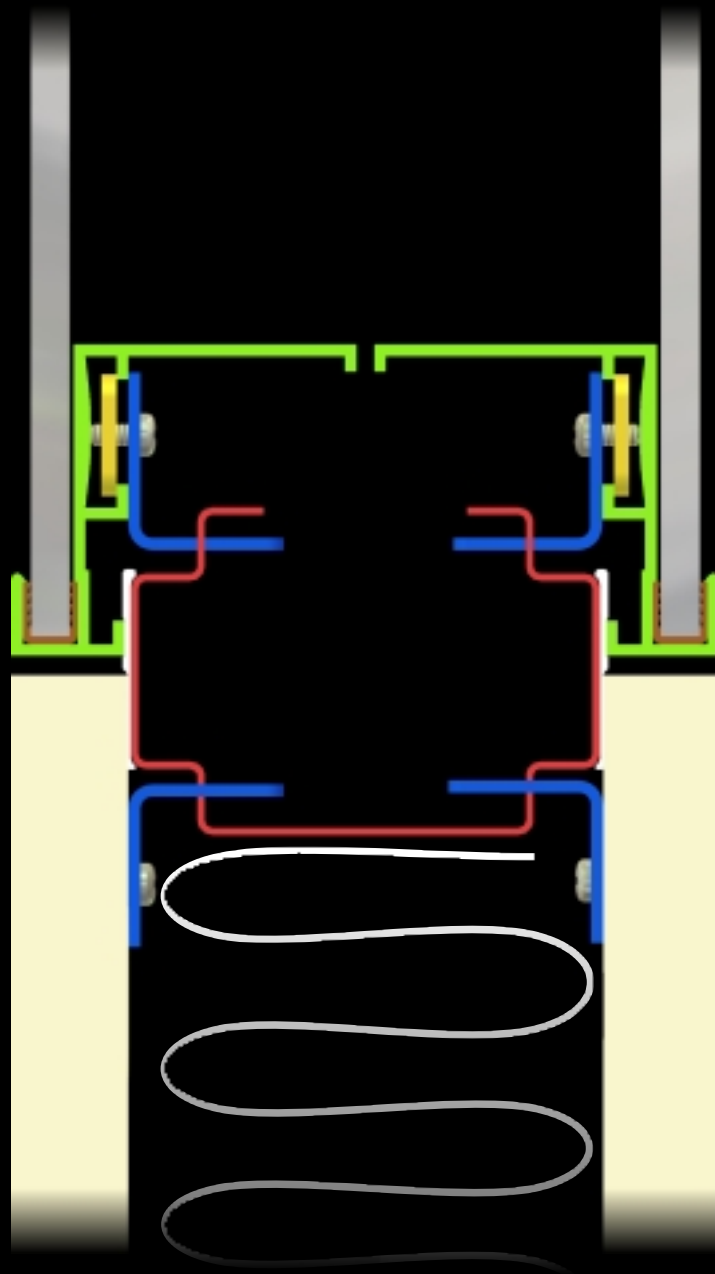

LINHA OFFICE
ESTRUTURA PARA
DIVISÓRIAS COM PLACA DE MADEIRA

LINHA OFFICE ROLL-FOR

Estrutura para Divisórias com placa de madeira ou Aço

Com a mais alta tecnologia em automação industrial, aliado a um atendimento personalizado e assessorado por uma equipe técnica profissional e capacitada.

A Roll-For oferece aos seus clientes soluções inteligentes em Divisórias, que viabilizam projetos de maneira rápida e rentável.

Características :

- * Sistema prático de montagem.
- * Saque frontal das placas: praticidade na montagem e facilidade na manutenção;
- * Opções variadas de angulação nos cantos.
- * Opções de vidro simples ou duplo, com introdução de persianas.
- * Calhas internas para passagem de fiação.
- * Bom isolamento acústico.

Matéria prima utilizada:

- * Aço zincado NBR 7008 zc
- * Processo contínuo de zincagem a fogo tipo sendzimir.
- * Aço base: 1008/1010
- * Espessuras: 0,43mm a 1,95mm

Pintura:

- * Contínua a pó, aplicação por processo eletrostático.
- * Tintas epóxi.

Embalagem:

- * Filme polietileno, plástico, papel Kraft, caixa de papelão e plástico bolha.

Roll-For
Soluções Inteligentes
e com a mais alta tecnologia
para sua casa ou escritório.

Índice por Categoria de Produtos

Divisória para Placa de Gesso

Detalhes

Canto 135°	Pg 05
Canto 90°	Pg 04
Canto "T"	Pg 06
Canto "X"	Pg 07
Batente de Alumínio	Pg 09
Detalhe de Canto para Vidro Duplo	Pg 13
Detalhe de Canto para Vidro Simples	Pg 13
Montagem das Placas de Gesso	Pg 16
Fixação da Estrutura na Parede	Pg 14
Fixação das Placas no Guia Piso	Pg 13
Fixação do Vidro com Presilha	Pg 14
Fixação do Esquadro Intermediário	Pg 13
Fixação do Montante no Guia Piso	Pg 10
Fixação do Montante no Guia Teto	Pg 10
Fixação do Vidro Duplo	Pg 12
Fixação do Vidro Duplo no Guia Piso	Pg 12
Fixação do Vidro Simples	Pg 11
Fixação do Vidro Simples no Guia Piso	Pg 11
Fixação do Vidro Total	Pg 15
Saída para parede	Pg 08

Componentes

Arremate de Alumínio	Pg 19
Arremate de Vidro Duplo	Pg 17
Arremate de Vidro Simples	Pg 17
Batente	Pg 22
Canto Externo 135°	Pg 18
Canto Externo 90°	Pg 18
Canto Interno 135°	Pg 18
Canto Interno 90°	Pg 18
Dobradiça	Pg 22
Esquadro 135°	Pg 20
Esquadro 90°	Pg 20
Esquadro Intermediário Guia Piso	Pg 19
Esquadro Intermediário Guia Teto	Pg 20
Esquadro Montante e Guia Piso	Pg 19
Esquadro Montante e Guia Teto	Pg 19
Esquadro "T"	Pg 20
Esquadro "X"	Pg 20
Fita PVC pro 101	Pg 21
Fita Vedadora Adesiva	Pg 22
Guarnição para Vidro	Pg 21
Guia Piso	Pg 17
Guia Teto	Pg 17
Montante	Pg 17
Presilha de Fixação do Arremate de Alumínio	Pg 21
Presilha de Fixação do Vidro	Pg 21
Suporte para Placa	Pg 21
Terminal Frontal	Pg 18
Travessa	Pg 17

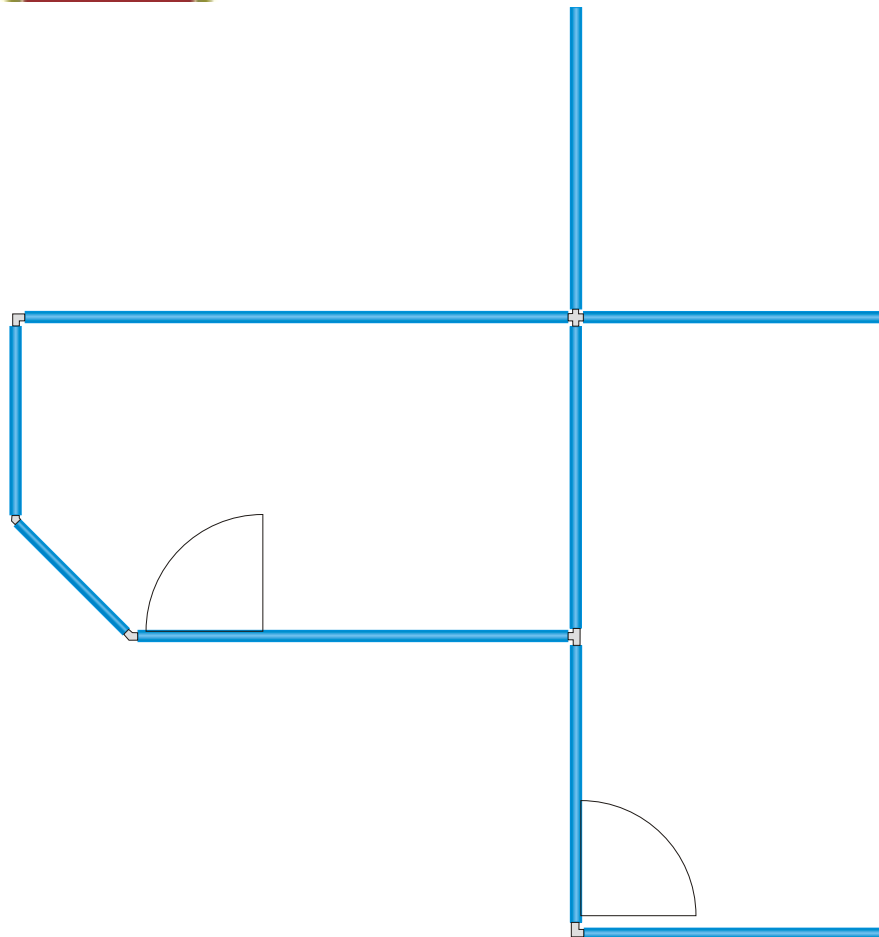
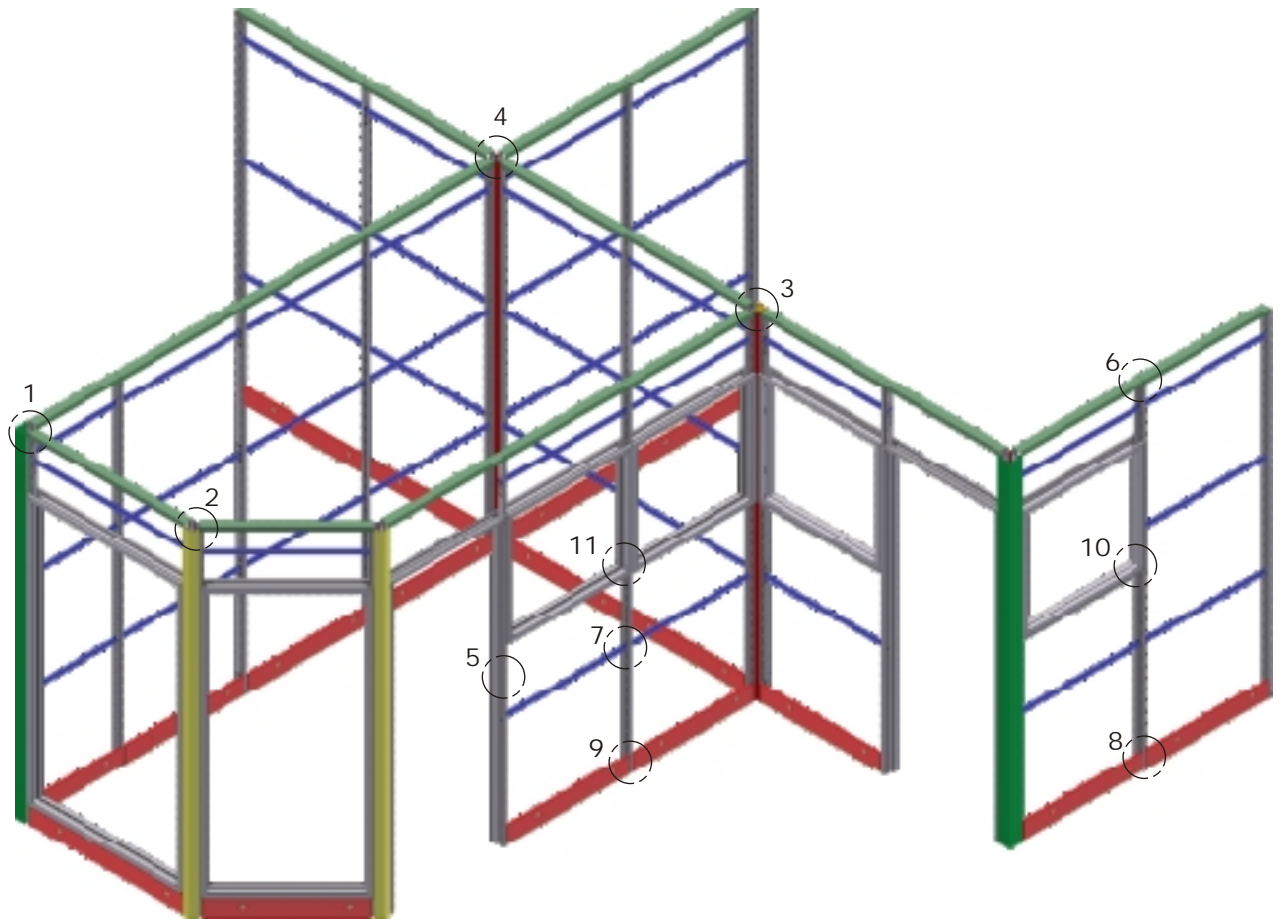

Detalhe "1A"
Canto 90°

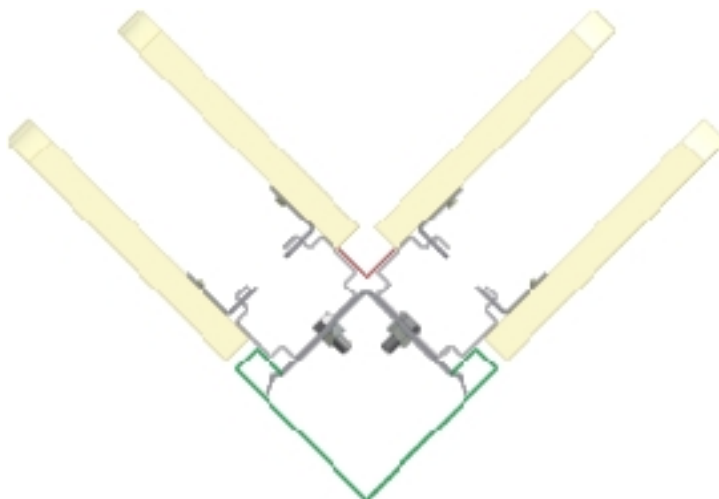
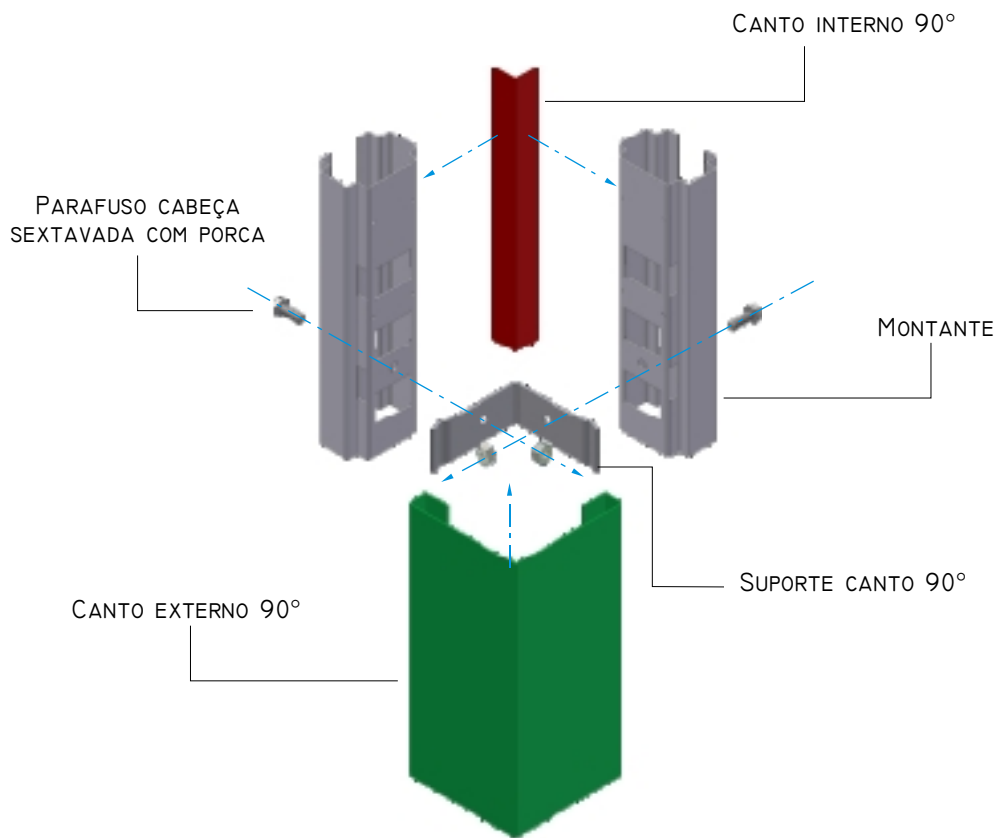
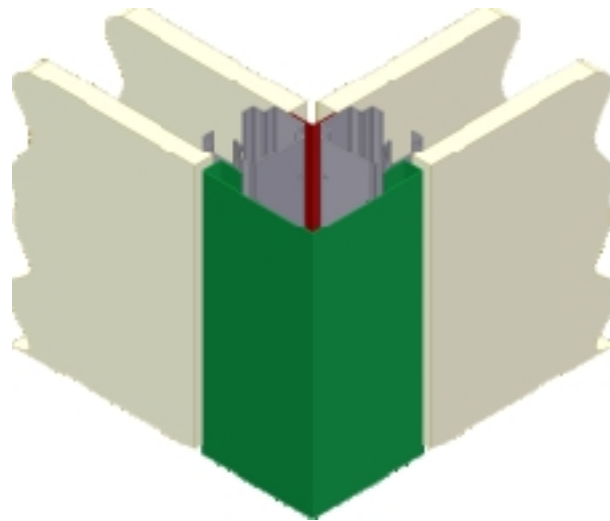

Detalhe "1 B"
Canto 90°

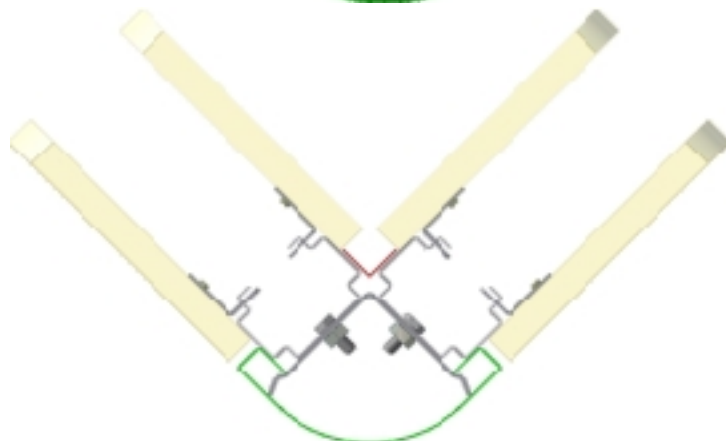
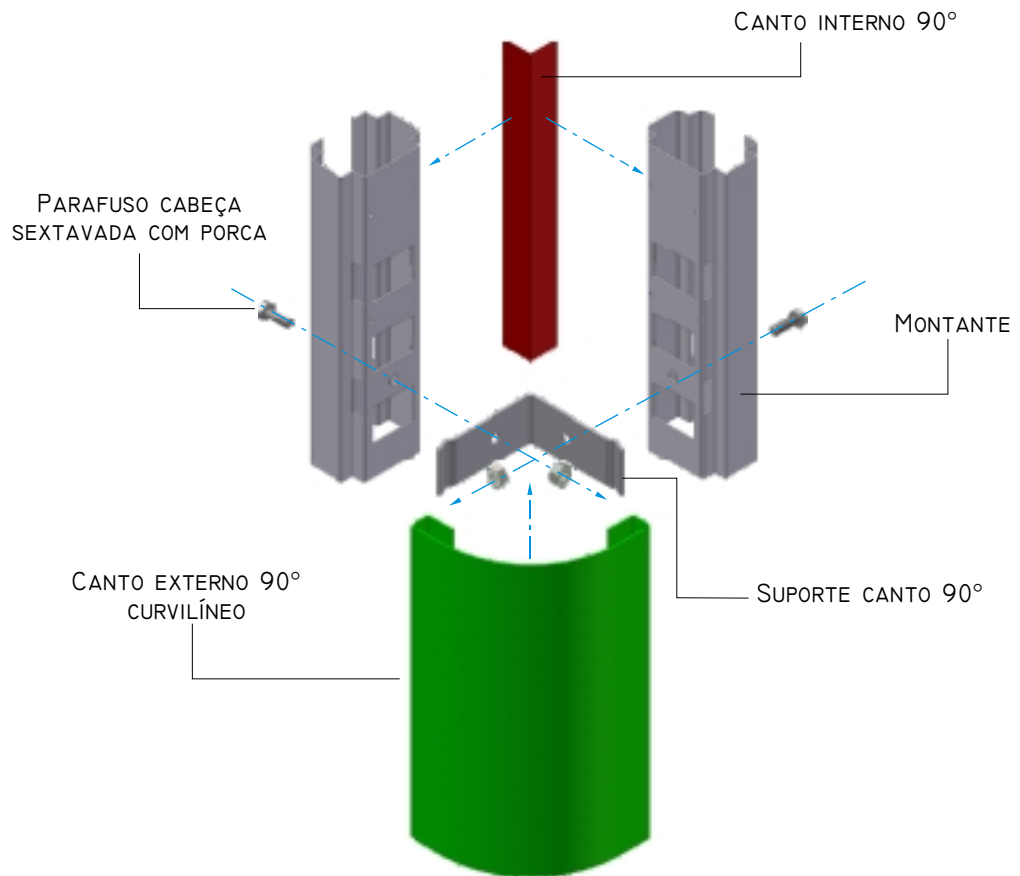
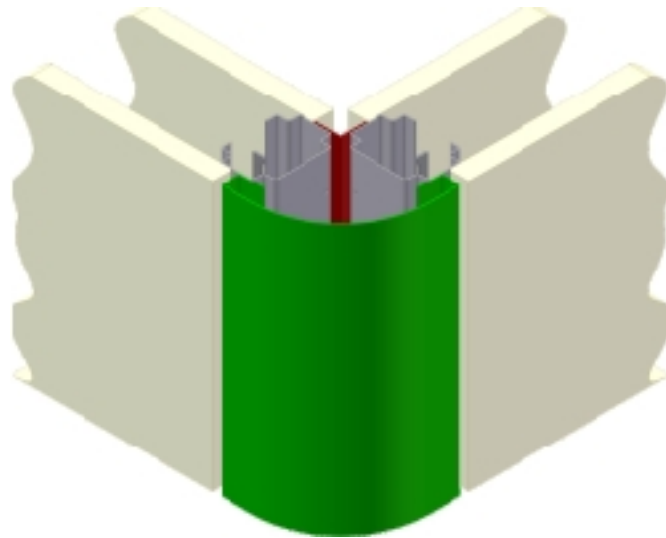

Detalhe "2A"
Canto 135°

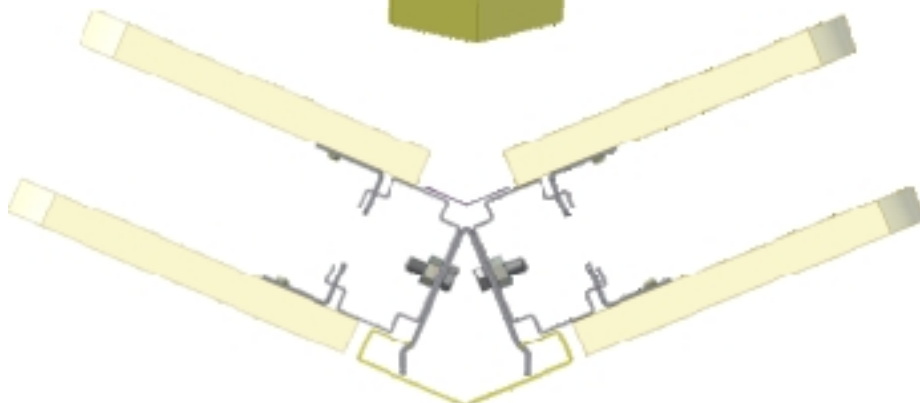
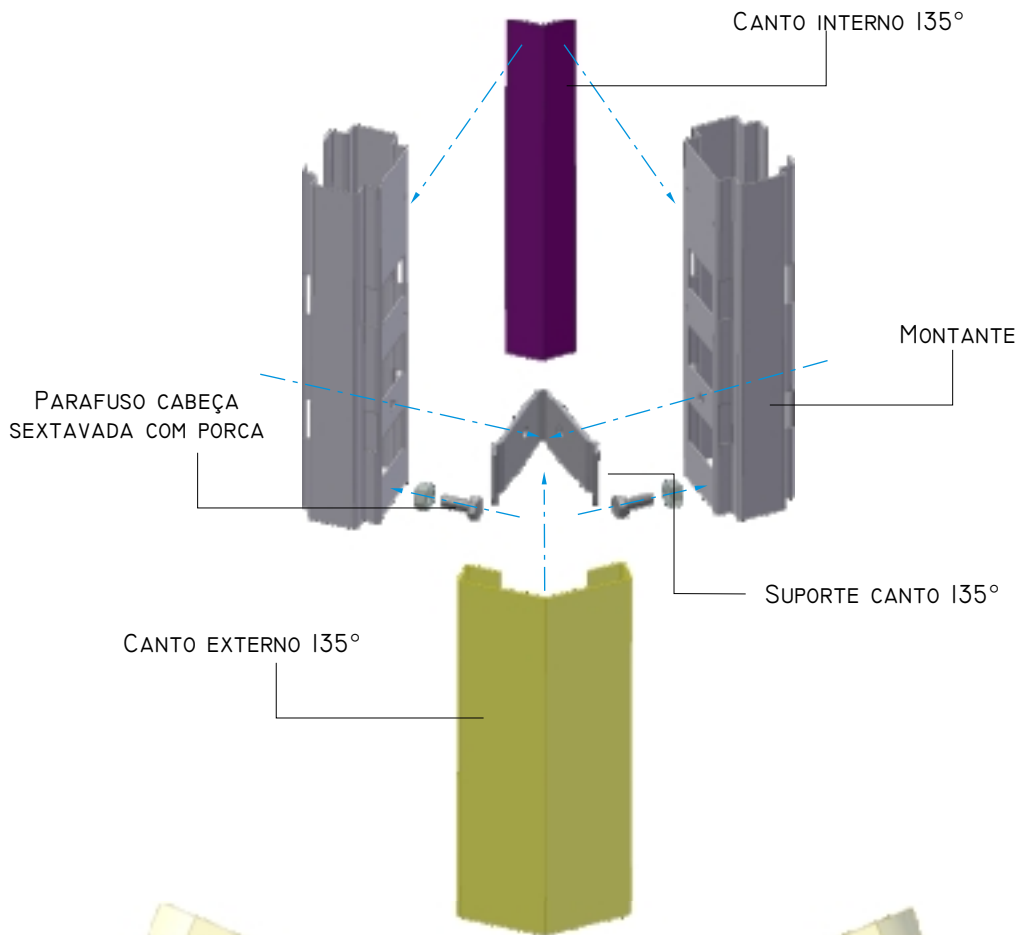
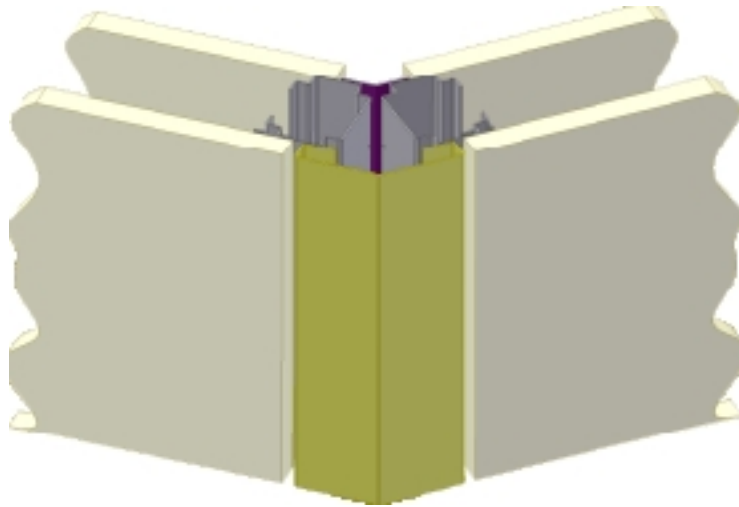

Detalhe "2B"
Canto 135°

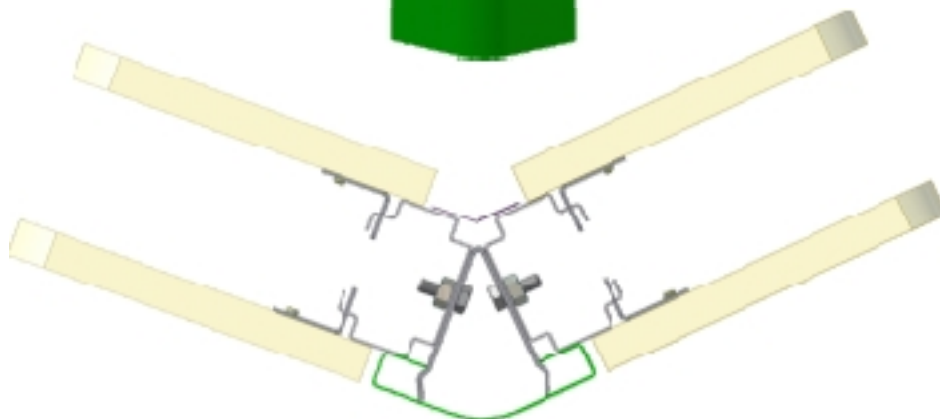
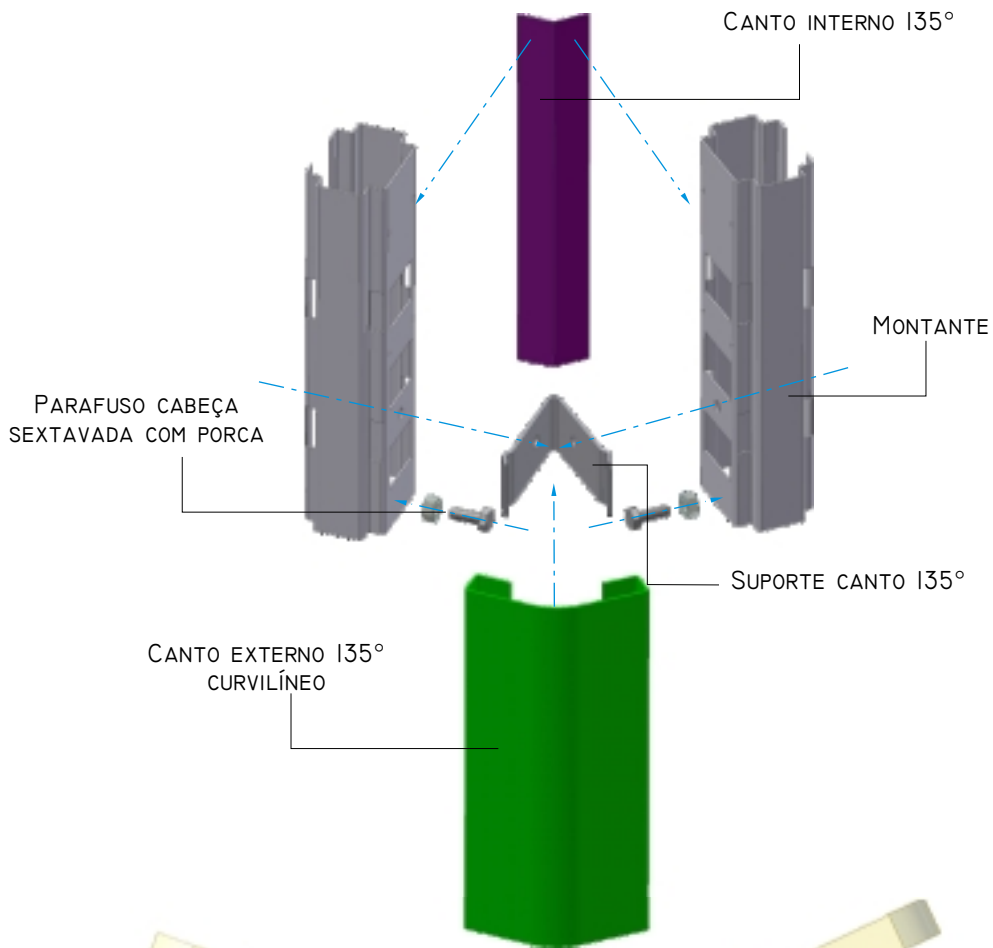
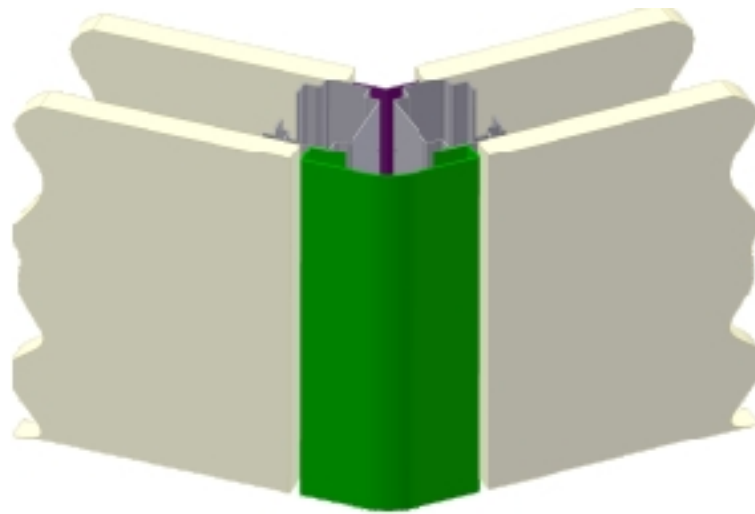

Detalhe "3"
Canto T

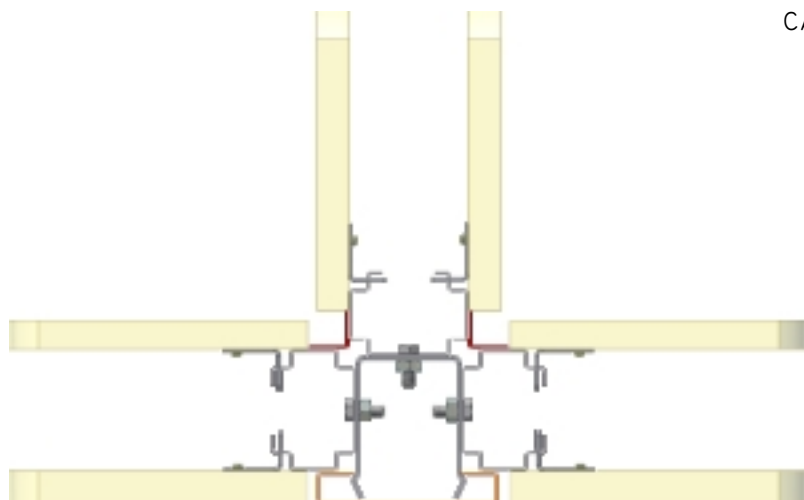
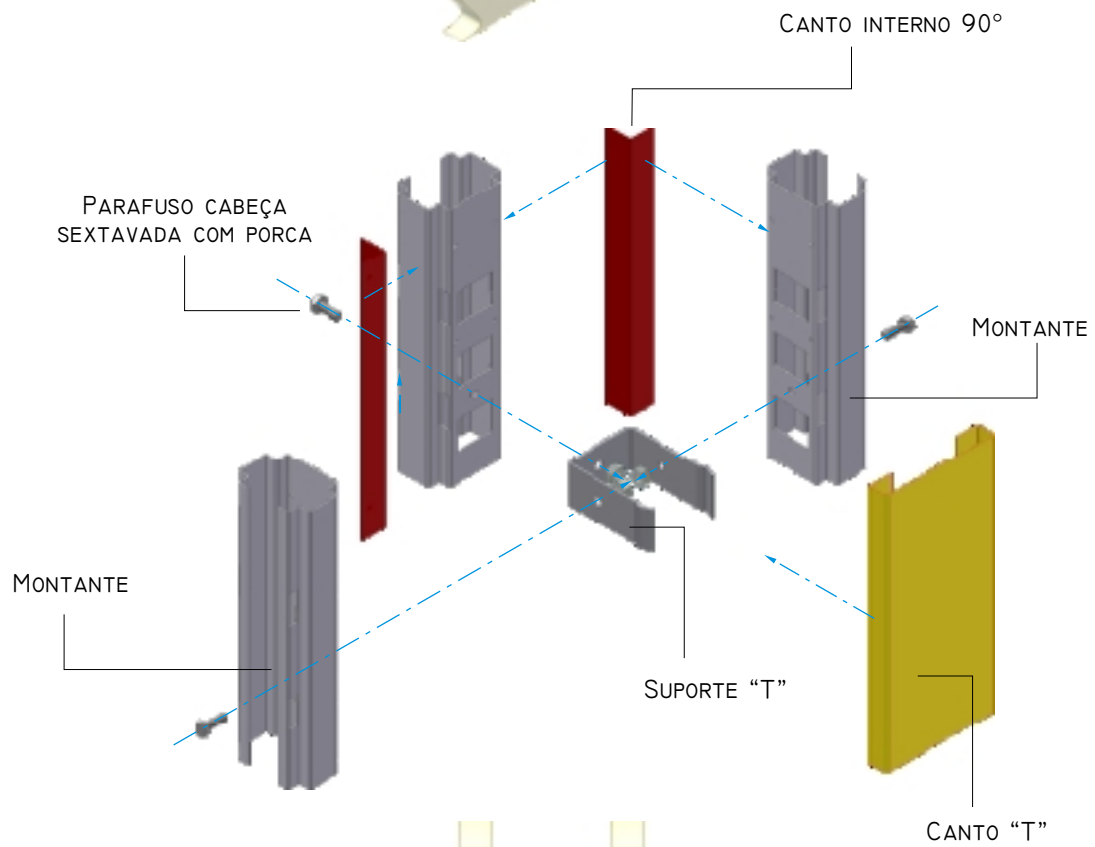
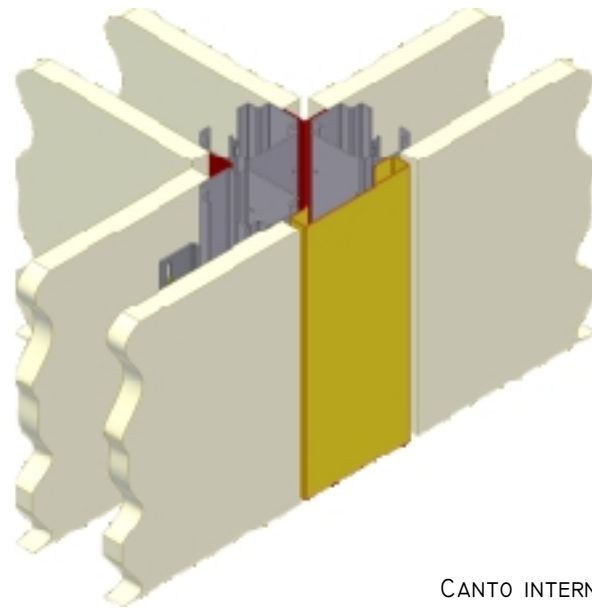

Detalhe "4"
Canto X

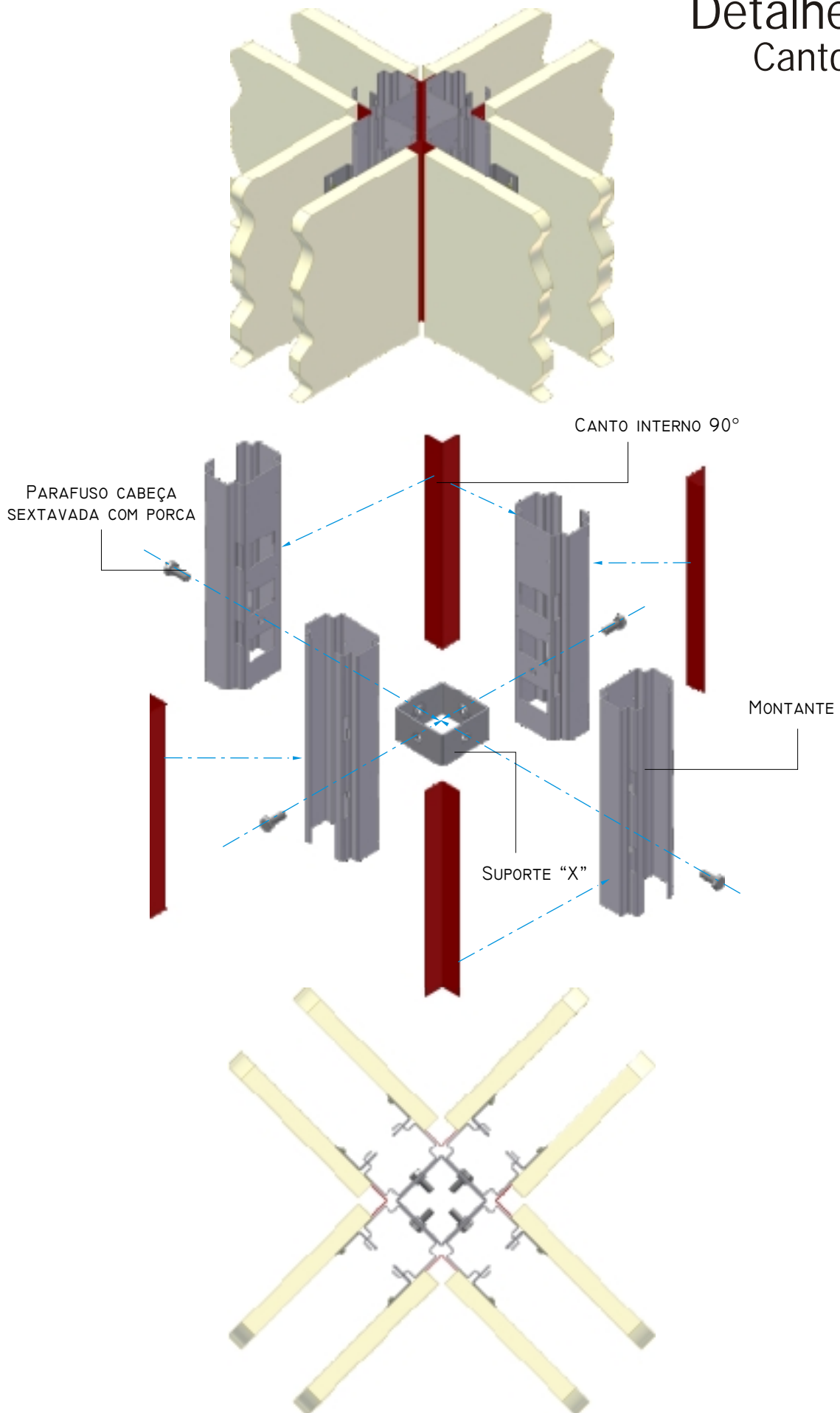

Detalhe "5"

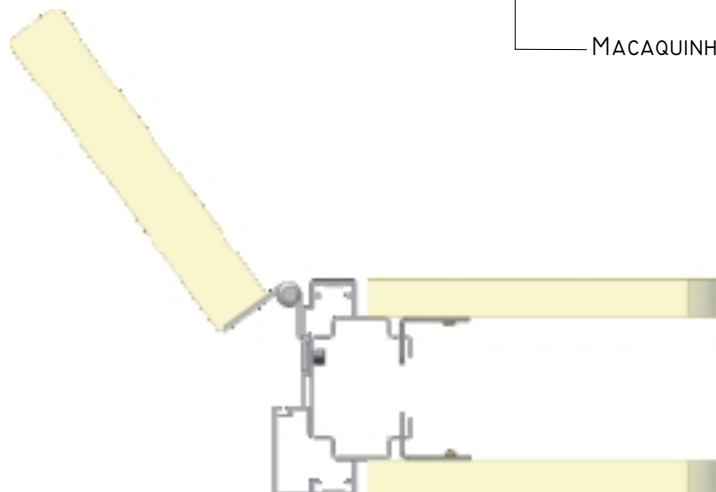
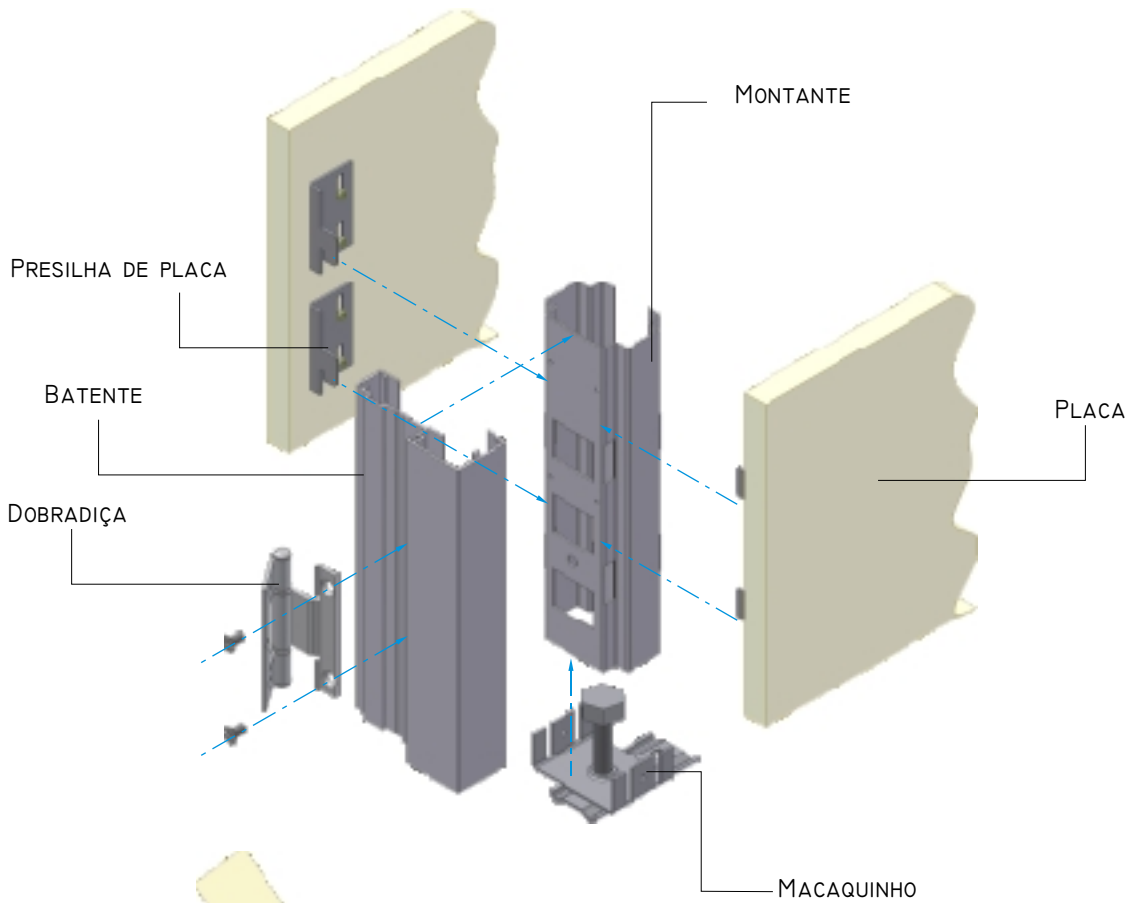
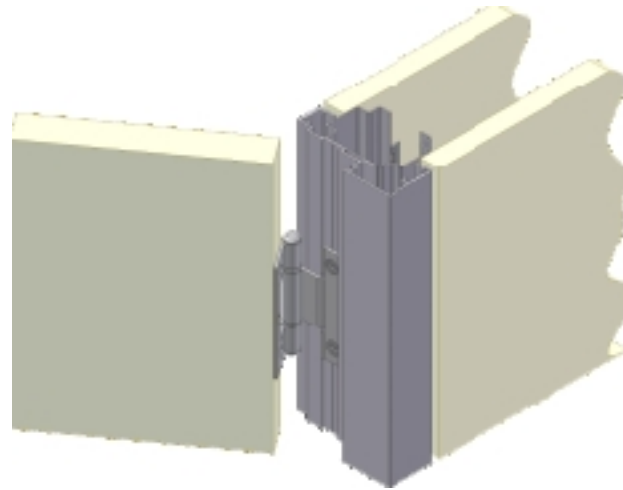

Detalhe "6"

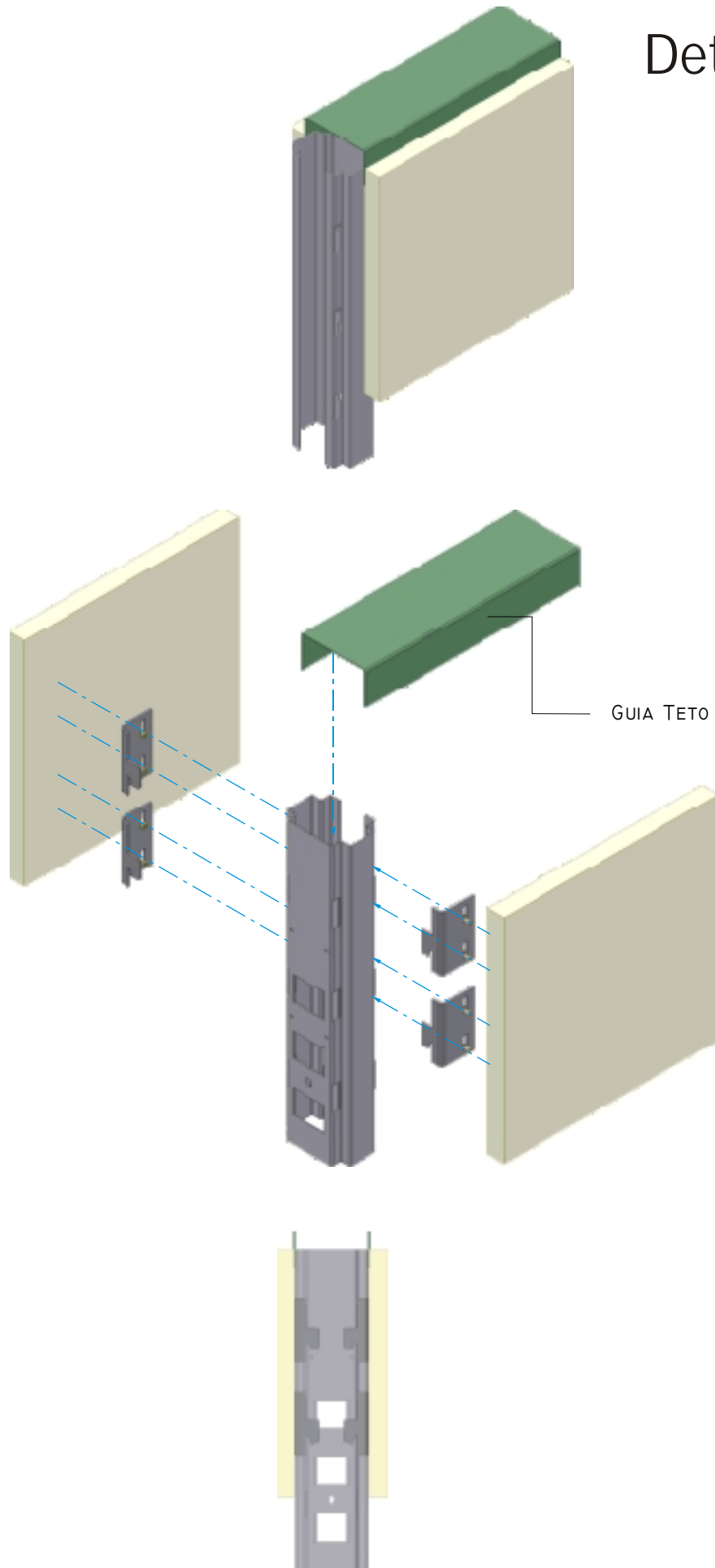

+

+

Detalhe "7"

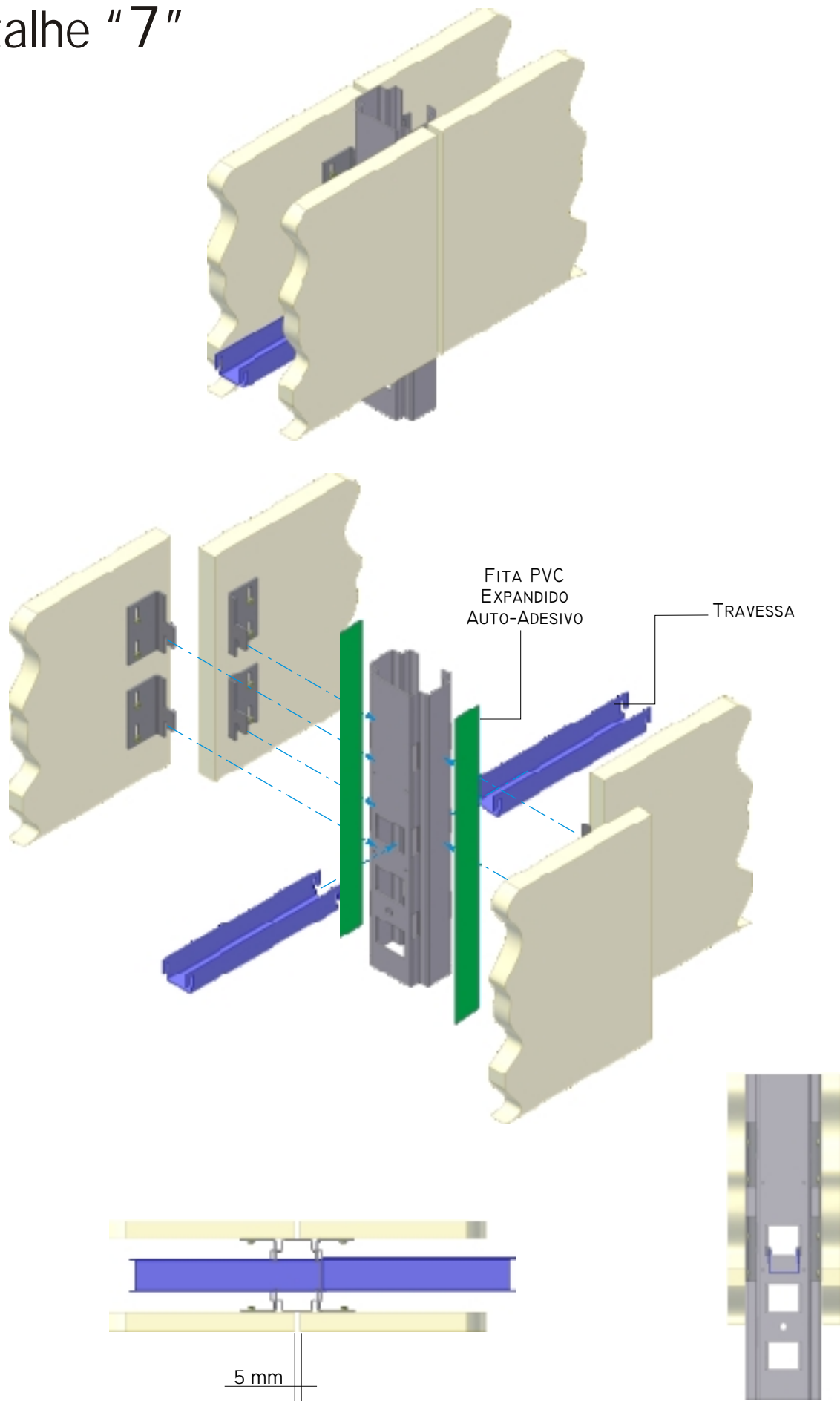

Detalhe "8"

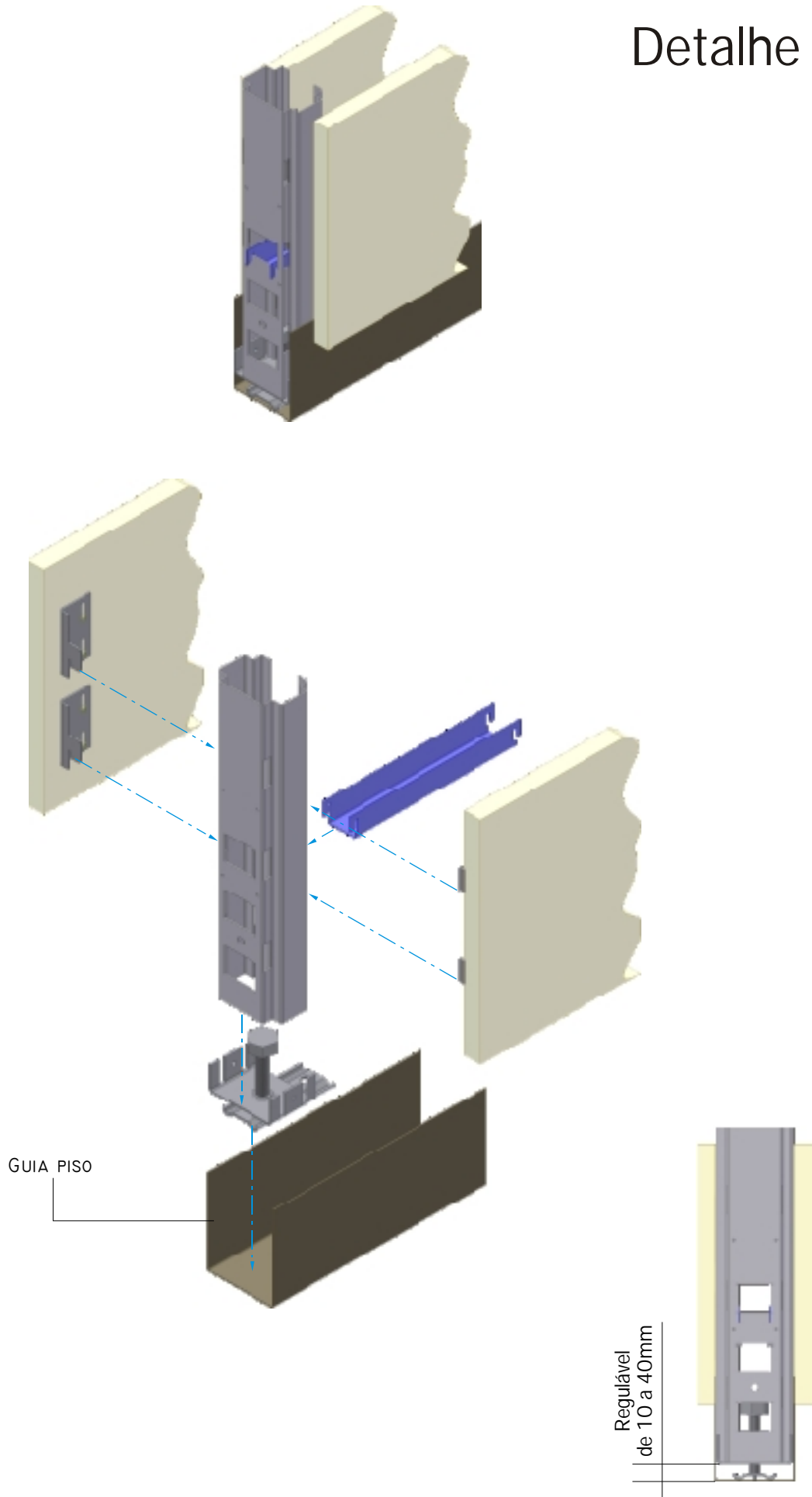

Detalhe "9"

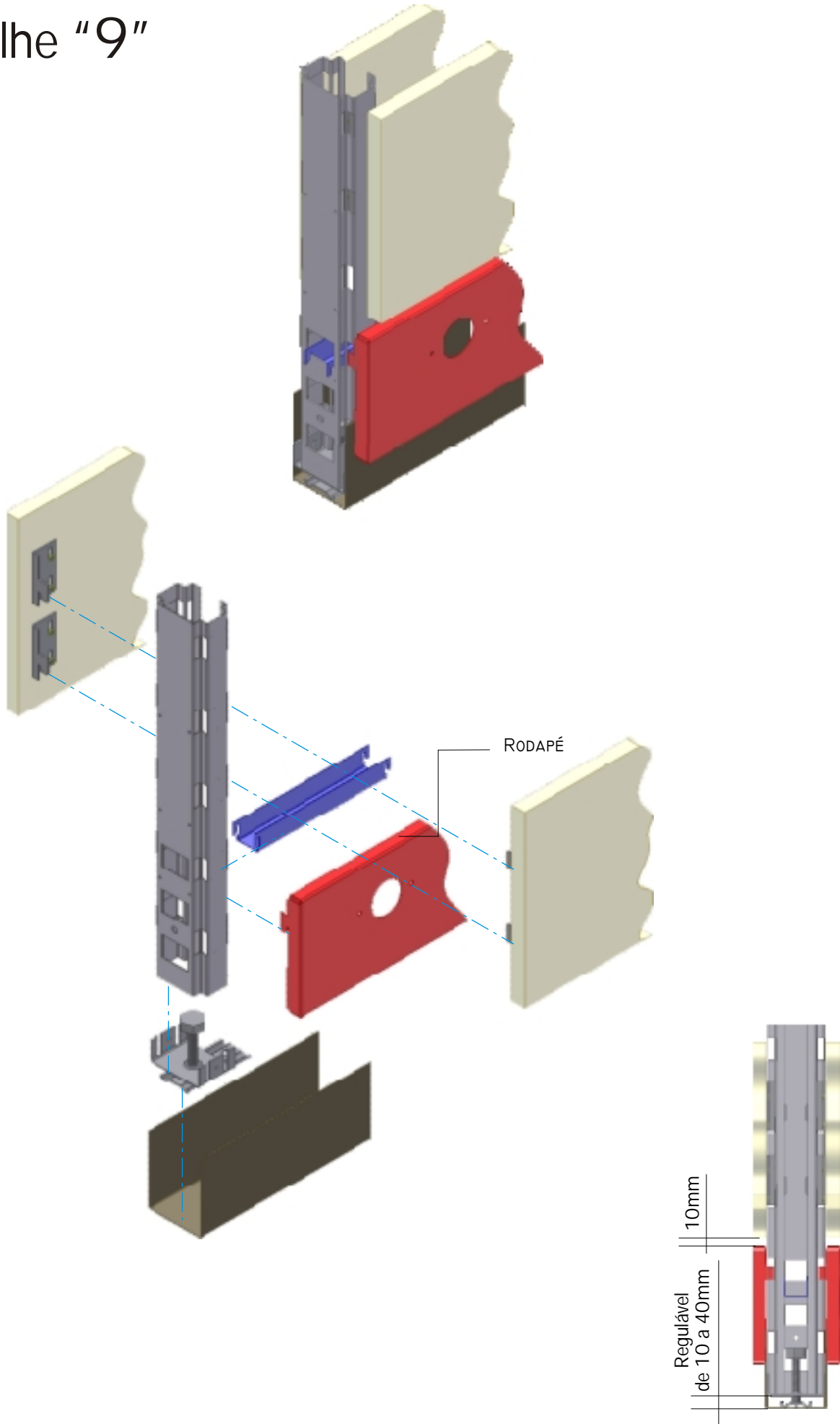

Detalhe "10"
Quadro de
Vidro Duplo

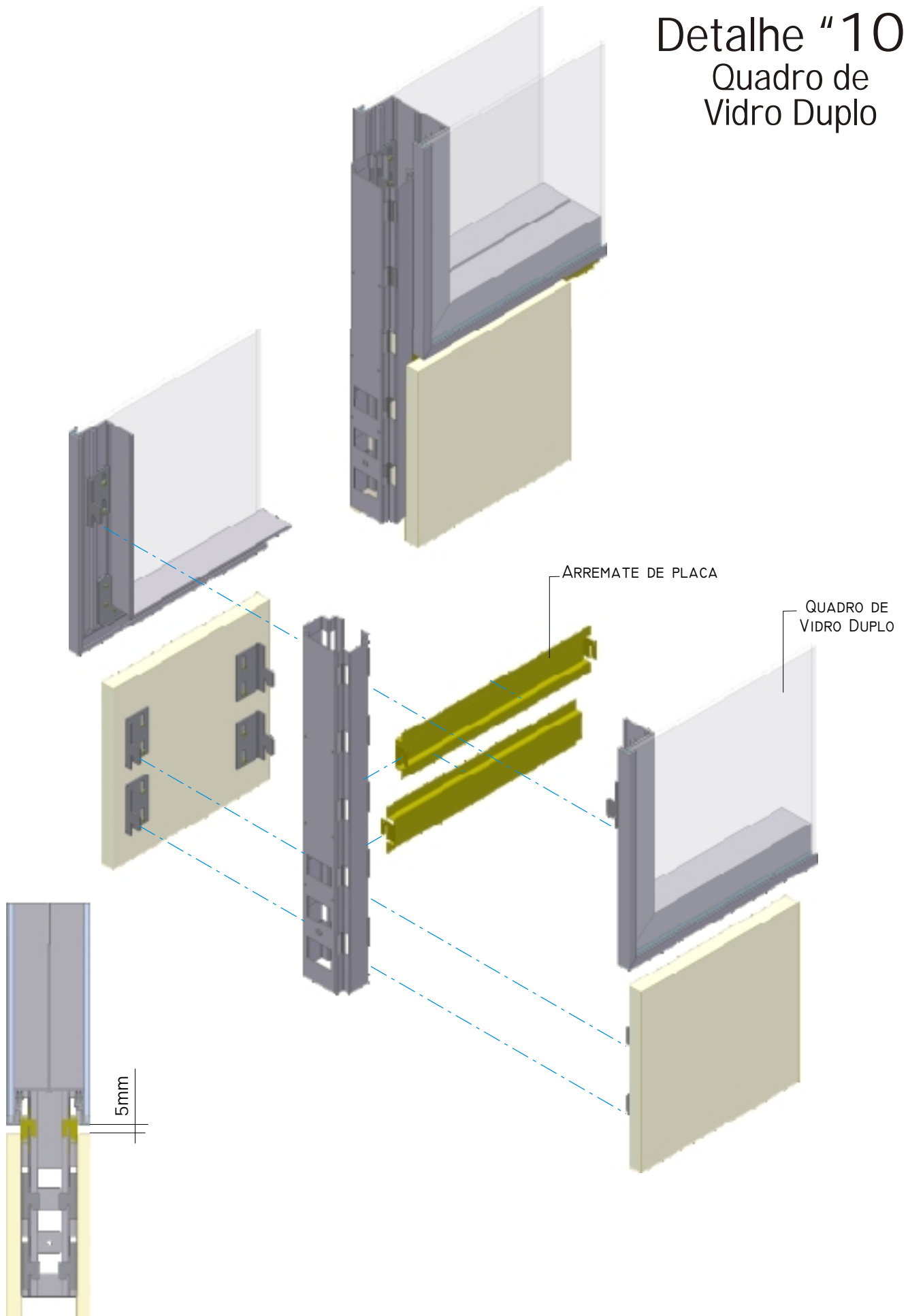

Detalhe "11"
Quadro de
Vidro Simples

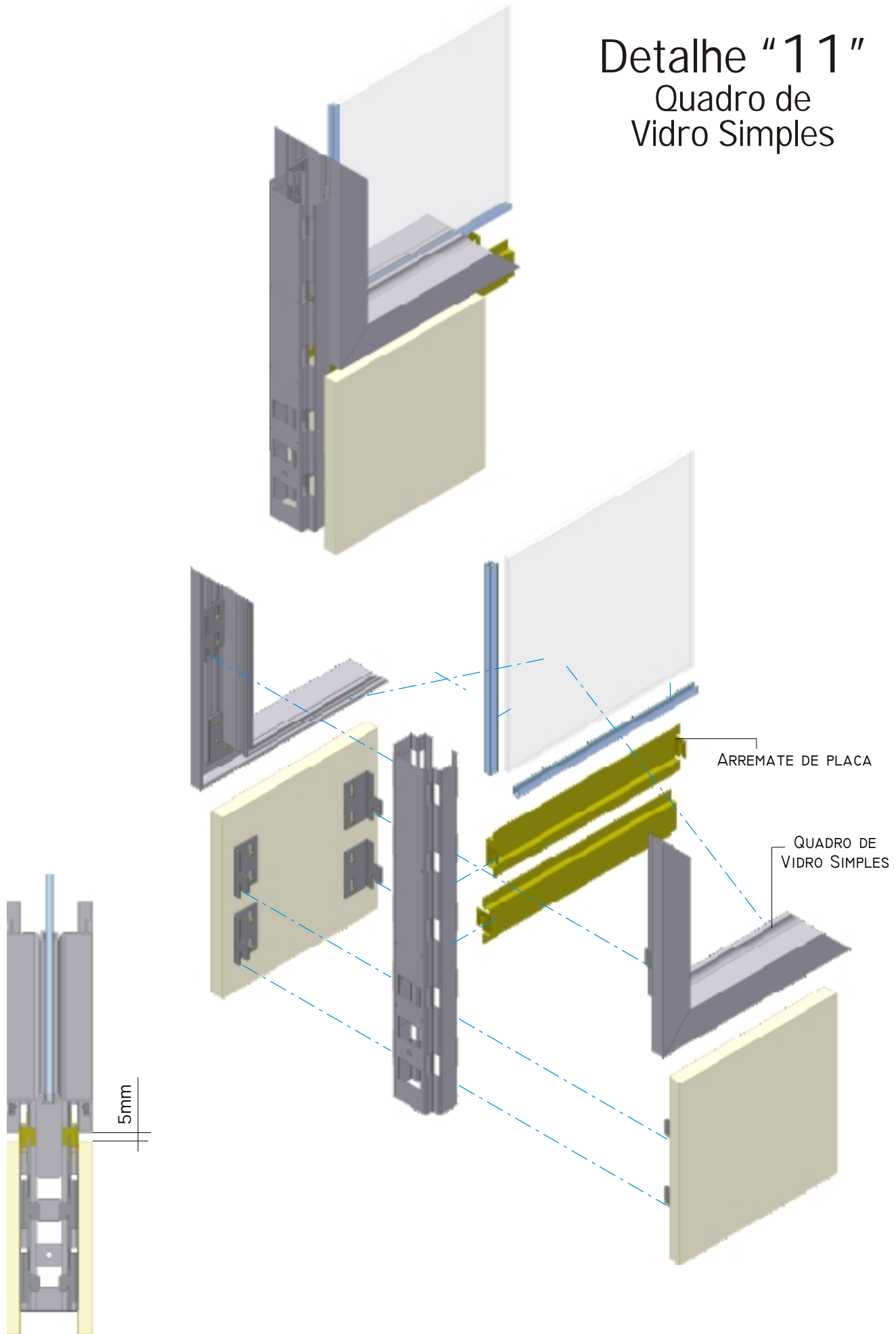

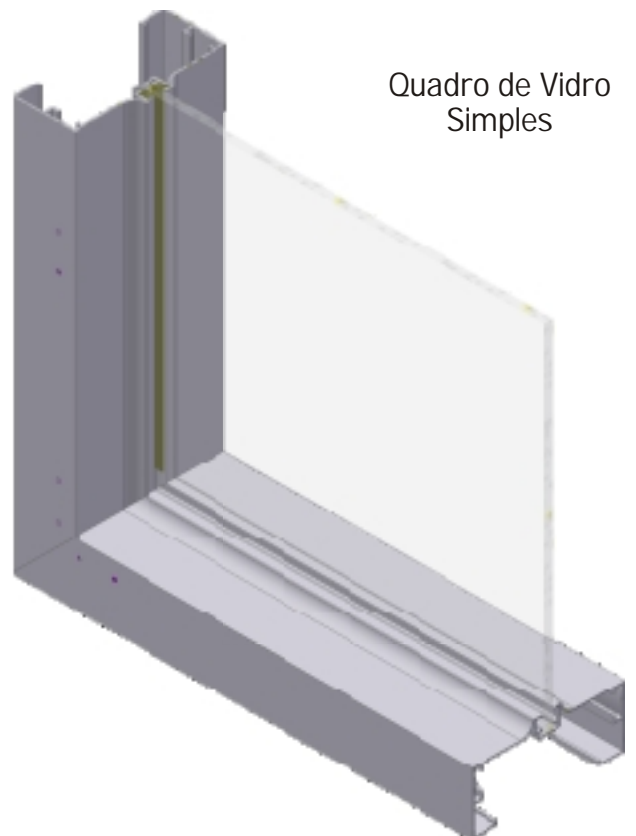
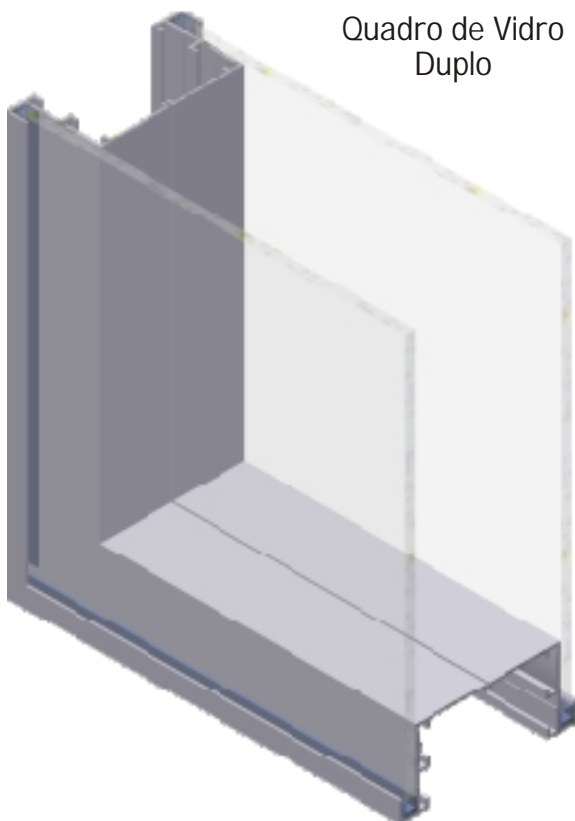
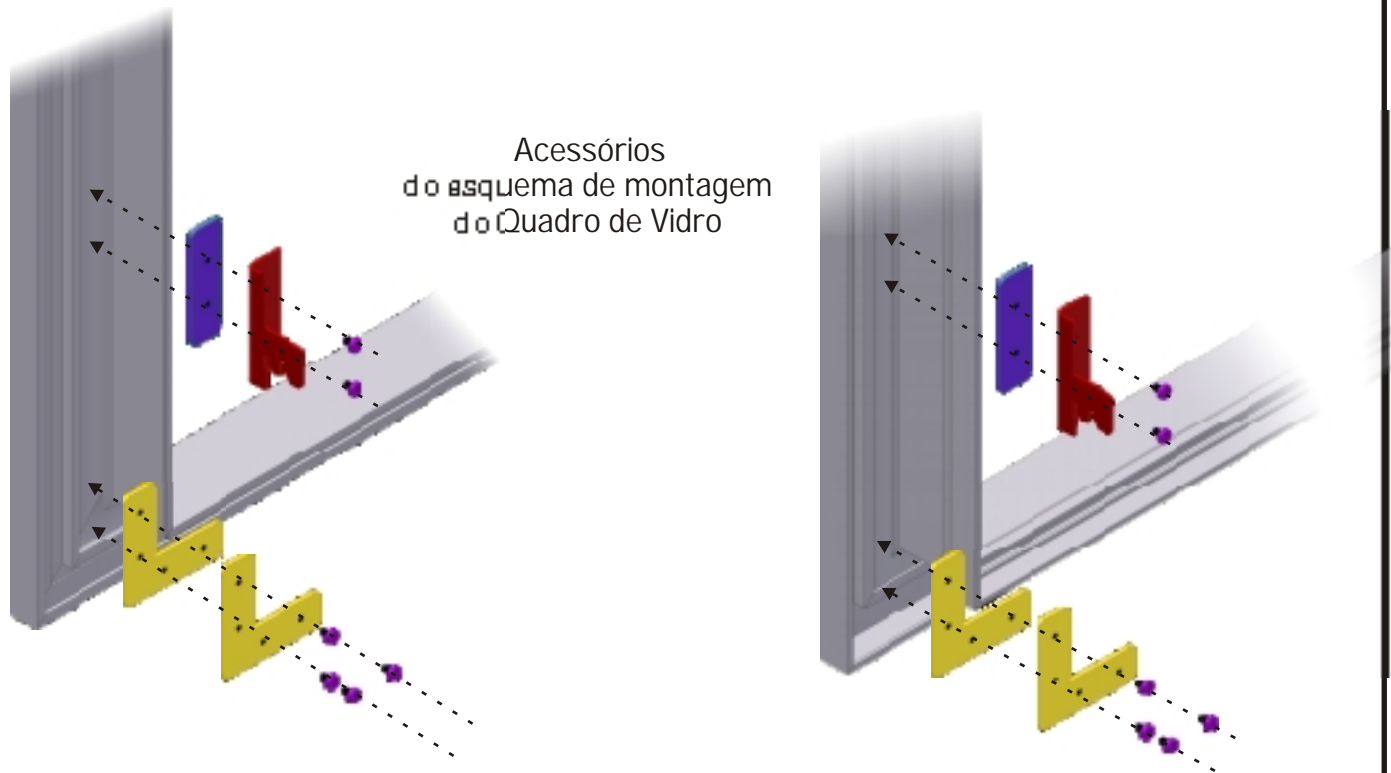

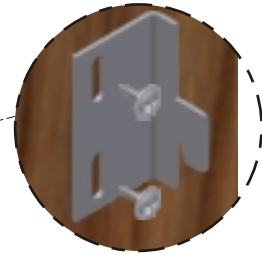

Fixação por meio de Parafusos
Atarrachados na Madeira



Presilha de
Placa Alta



Presilha de
Placa Baixa

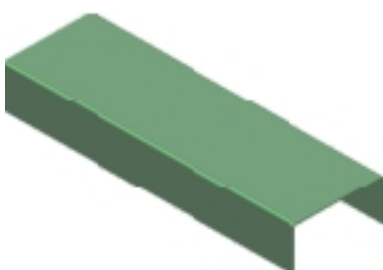

Presilha de
Placa Baixa

PRODUTO	CÓDIGO	DENOMINAÇÃO	DIMENSÕES (mm)	OBS:
	G91.302		3000	
	G91.301	MONTANTE 60x42 <small>210-3-526</small>	2800	
	G91.300		2600	
	G91.299		2500	
	851.696	GUIA PISO C/FT 60x80 <small>210-4-349</small>	3000	
	825.633	GUIA PISO S/FT 60x80 <small>210-4-349/A</small>	3000	
	A99.232	GUIA TETO 60x30 <small>210-4-350</small>	3000	
	A99.231	GUIA VERTICAL 60x40 <small>210-4-366</small>	3000	
	827.640		1252	
	827.641		1052	
	827.642	TRAVESSA (RECORTE) 25x20 <small>210-4-348/A</small>	952	
	827.305		980	
	827.306		880	
	827.797		100	
	827.637		1200	
	827.638	TRAVESSA 25x20 <small>210-4-348</small>	1000	
	827.639		900	

PRODUTO	CÓDIGO	DENOMINAÇÃO	DIMENSÕES (mm)	OBS:
	846.671	CANTO EXTERNO 90° <small>210-4-352</small>	3000	
	846.672		2800	
	846.673		2600	
	846.674		2500	

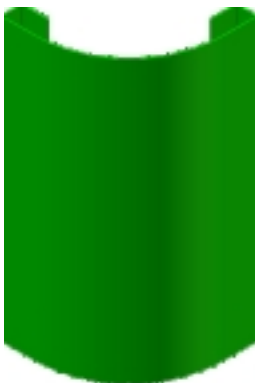
	L72.485	CANTO EXTERNO CURVO 90° <small>210-i-600/1</small>	3000	
	L72.486		2800	
	L72.487		2600	
	L72.488		2500	

	847.678	CANTO INTERNO 90° <small>210-4-385</small>	3000	
	847.677		2800	
	847.676		2600	
	847.675		2500	

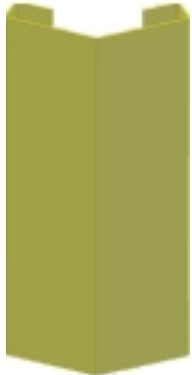
PRODUTO	CÓDIGO	DENOMINAÇÃO	DIMENSÕES (mm)	OBS:
	944.113		3000	
	944.114	CANTO EXTERNO 135° 210-4-352/B	2800	
	944.115		2600	
	944.116		2500	

	L73.489		3000	
	L73.490	CANTO EXTERNO CURVO 135° 210-4-600/2	2800	
	L73.491		2600	
	L73.492		2500	

	945.117		3000	
	945.118	CANTO INTERNO 135° 210-4-365	2800	
	945.119		2600	
	945.120		2500	

PRODUTO	CÓDIGO	DENOMINAÇÃO	DIMENSÕES (mm)	OBS:
	E67.201		3000	
	E67.202	ARREMATE FRONTAL 90x28,5 <small>210-3-472</small>	2800	
	E67.205		2600	
	E67.204		2500	
		830.646		3000
830.647		CANTO "T" 90x15 <small>210-4-401</small>	2800	+
830.648			2600	
830.649			2500	
		E60.901	MACAQUINHO <small>210-3-471</small>	-
  PERFIL	G92.307		2150x880	
	G92.308		2500x880	
	G92.309		2600x880	
	G92.280		2800x880	
	G92.310	BATENTE <small>210-3-476/E</small>	3000x880	
	G92.311		2150x980	
	G92.312		2150x980	
	G92.313		2150x980	
	G92.281		2150x980	
	G92.314		2150x980	

PRODUTO	CÓDIGO	DENOMINAÇÃO	DIMENSÕES (mm)	OBS:
	829.644	SUPORTE CANTO 90° <small>210-4-347</small>	-	

	829.645	SUPORTE CANTO 135° <small>210-4-352/B</small>	-	

	829.739	SUPORTE "T" <small>210-4-347/C</small>	-	

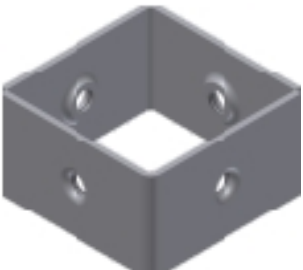
	F29.934	SUPORTE "X" <small>210-4-347/E</small>	-	

	C45.680	PARAFUSO CABEÇA SEXTAVADA COM PORCA	-	

PRODUTO	CÓDIGO	DENOMINAÇÃO	DIMENSÕES (mm)	OBS:
	211.759	PRESILHA DE PLACA 215-4-418	BAIXA	
	211.760		ALTA	

	G03.693	ARREIMATE DE PLACA CARTOLA 25x8,5 215-4-374	1200	+
	G03.693		1000	
	G03.693		900	

	G71.172	RODAPÉ COM FUROS PARA TOMADA 215-3-527/B	1200	+
	G71.170		1000	
	G71.169		900	

	G70.154	RODAPÉ SEM FUROS PARA TOMADA 215-3-527/C	1200	
	G70.156		1000	
	G70.157		900	

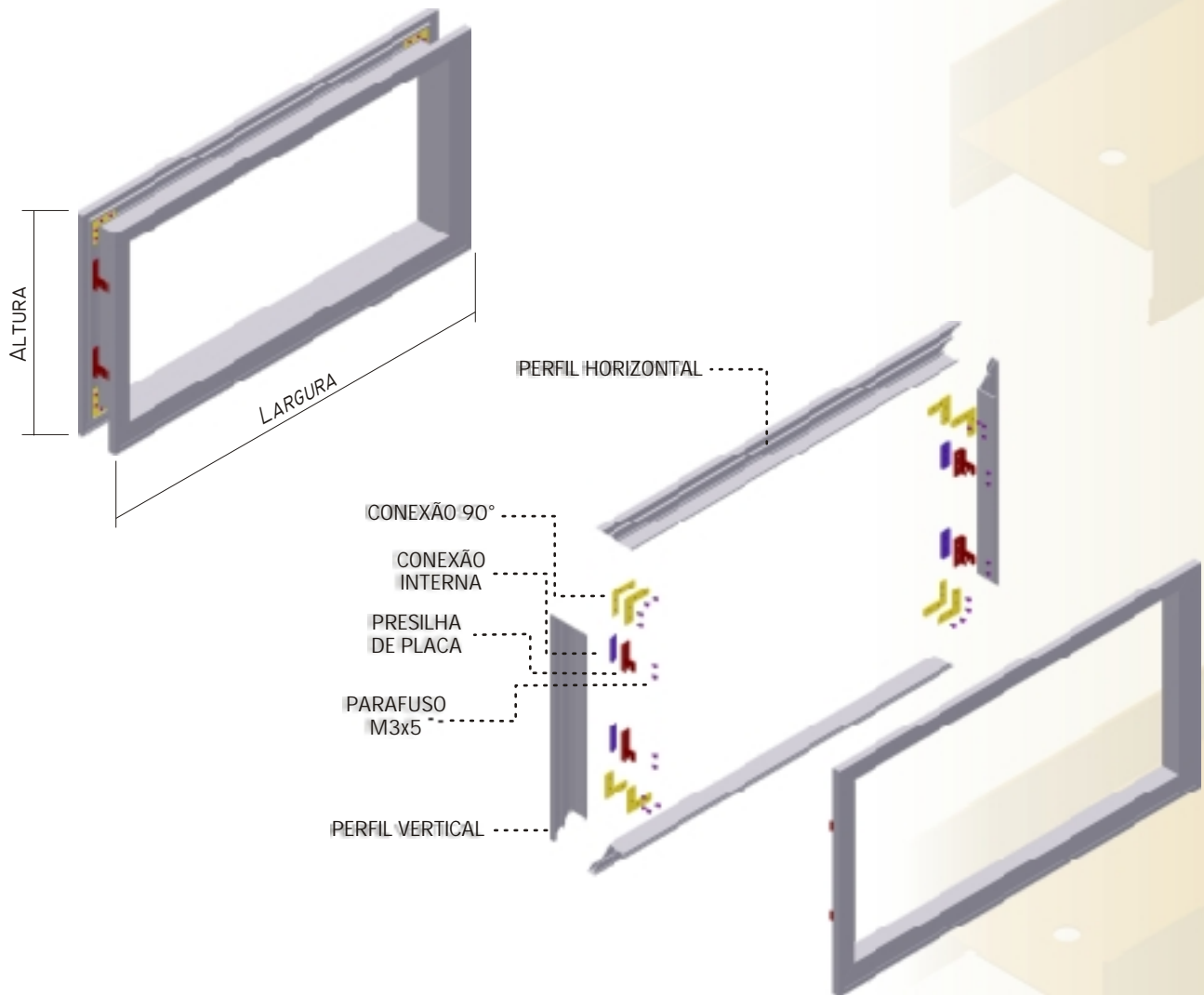

CÓDIGO	DENOMINAÇÃO	DIMENSÕES (mm) (Largura x Altura)	OBS:
G88.288		900-895x2005	
G88.289	QUADRO DE VIDRO TOTAL <small>210-3-476/C</small>	1000-995x2005	
G88.290		1200-1195x2005	

G89.291		900-895x1071	
G89.292	QUADRO 1/2 VIDRO <small>210-3-476/C</small>	1000-995x1071	
G89.293		1200-1195x1071	

G90.294		900-895x840	
G90.295		1000-995x840	
G90.296	BANDEIRA <small>210-3-476/C</small>	1000-995x840	
G90.297		1000-995x840	
G90.298		1200-1195x840	

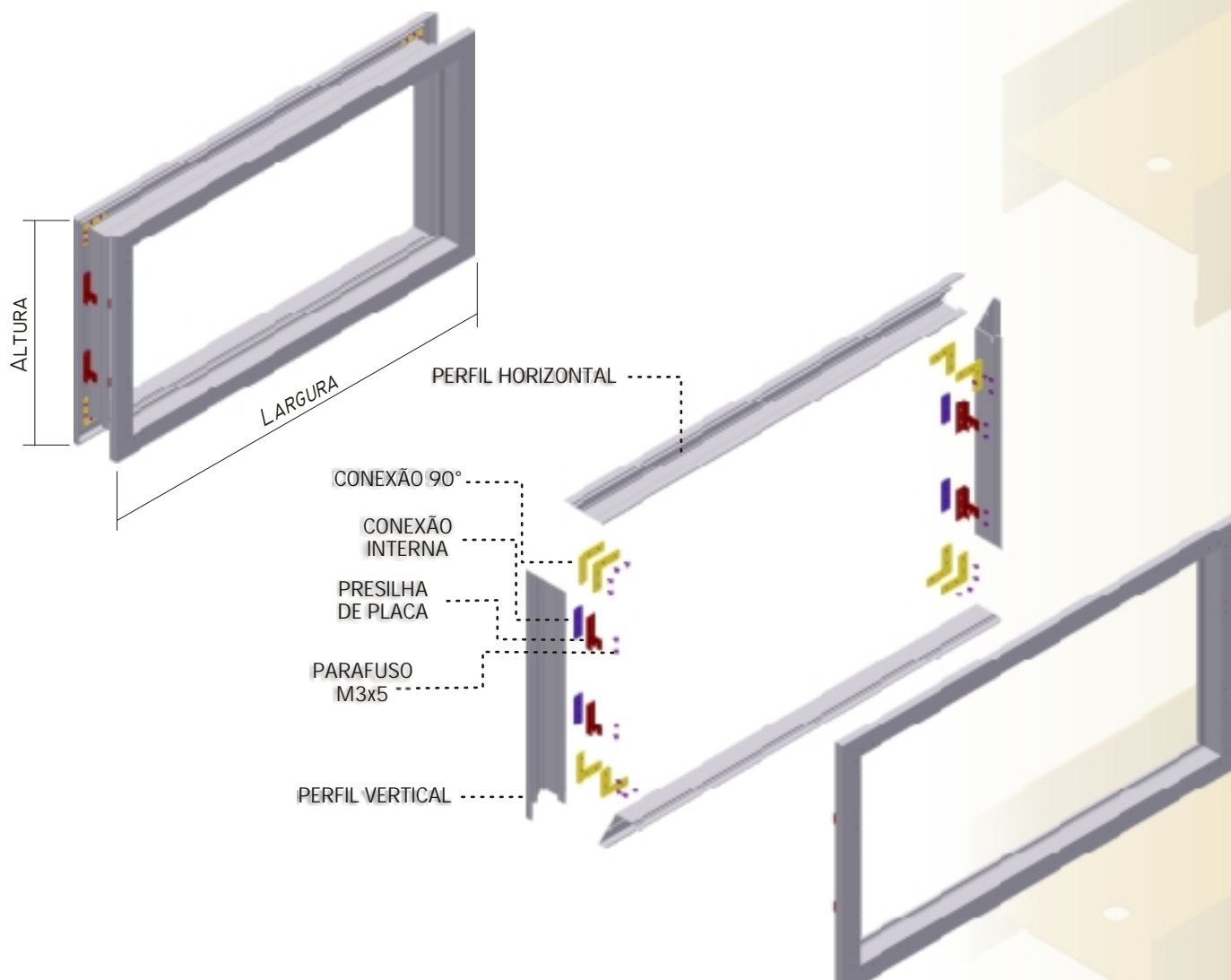

CÓDIGO	DENOMINAÇÃO	DIMENSÕES (mm) (Largura x Altura)	OBS:
G85.277		900-895x2005	
G85.278	QUADRO DE VIDRO TOTAL <small>210-3-476/D</small>	1000-995x2005	
G85.279		1200-1195x2005	

G86.280		900-895x1071	
G86.281	QUADRO ½ VIDRO <small>210-3-476/D</small>	1000-995x1071	
G86.282		1200-1195x1071	

G87.283		900-895x840	
G87.284		1000-995x840	
G87.285	BANDEIRA <small>210-3-476/D</small>	1000-995x840	
G87.286		1000-995x840	
G87.287		1200-1195x840	



RF **ROLL
FOR**

Rua: Arthur Carl Schmidt, 175 - CEP: 07222-050
Cumbica - Guarulhos - SP - Brasil
www.rollfor.com.br e-mail: rollfor@rollfor.com.br
Tel:(11) 6462-1500 FAX: (11) 6462-1535